

FITTING INSTRUCTION

Clamp mark in acc. with		Cables joining
ISO	PN	
1	L	Left directional lights
2	+	Rear fog lights
3	31	Ground
4	R	Right directional lights
5	58R	Right side parking lights
6	54	Stoplights
7	58L	Left side parking lights

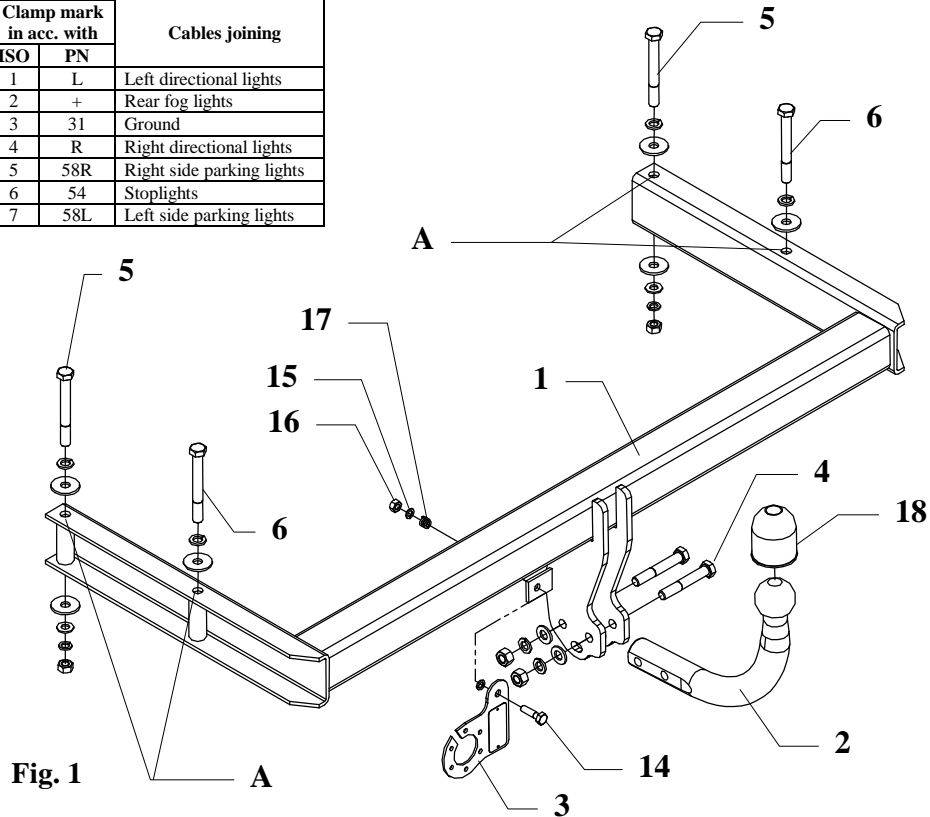

This towbar is designed to assembly in following car:
SKODA SUPERB, produced since 2002 till 08.2008, catalogue number **H08** and is prepared to tow trailers max total weight **1600kg** and max vertical mass **75kg**.

From manufacturer

Thank you for buying our product. Their reliability has been confirmed in many tests. Reliability of towbar depends also on correct assembly and right operation. For this reasons we kindly ask to read carefully this instruction and apply to hints.

The towbar should be install in points described by a car producer.

The instruction of the assembly

1. Disassemble the rear bumper and metal support (this part is not used any more)
2. Slide bar of the towbar (pos. 1) to the chassis member in this way so holes pos. A agree with original holes in chassis members and fix it using bolts M10x100mm (pos. 5) and M10x110mm (pos. 6).
3. Reassemble the rear bumper
4. Fix tow-ball (pos. 2) using bolts M12x75mm (pos. 4) from towbar accessories.
5. Fix the socket plate (pos. 3) as shown on the drawing.
6. Fix tight all bolts according to the torque shown in the table.
7. Connect the electric wires according to the instructions of the car.
8. Complete the paint cover of towbar (during the mounting paint cover could be destroyed).

Torque settings for nuts and bolts (8,8):

M 8 25 Nm

M 10 55 Nm

M 12 85 Nm

M 14 135 Nm











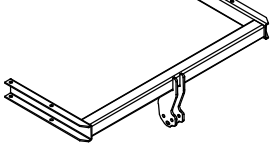
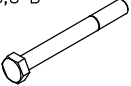



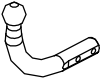

NOTE

After install the towbar you should get adequate note in registration book (at authorised service station).The car should be equipped with:

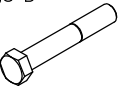
- Indicators
- Tow mirrors

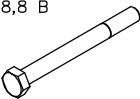
After 1000km of exploitation check all bolts and nuts. The ball of towbar must be always kept clear and conserve with a grease.

Towbar accessories:

Pos. 1 Name: Main bar Quantity: 1 	Pos. 6 Name: Bolt 8,8 B Quantity: 2 Dim.: M10x100 	Pos. 12 Name: Spring washer Quantity: 2 Dim.: Ø 12,2 mm 
	Pos. 7 Name: Nut 8 B Quantity: 2 Dim.: M12 	Pos. 13 Name: Spring washer Quantity: 6 Dim.: Ø 10,2 mm 
Pos. 2 Name: Tow ball Quantity: 1 	Pos. 8 Name: Nut 8 B Quantity: 2 Dim.: M10 	Pos. 14 Name: Bolt 8,8 B Quantity: 1 Dim.: M8x30mm 
Pos. 3 Name: Socket plate Quantity: 1 	Pos. 9 Name: Washer Quantity: 6 Dim.: Ø35xØ12x3mm 	Pos. 15 Name: Plain washer Quantity: 2 Dim.: Ø 8,5 mm 
Pos. 4 Name: Bolt 8,8 B Quantity: 2 Dim.: M12x75mm 	Pos. 10 Name: Plain washer Quantity: 2 Dim.: Ø 13 mm 	Pos. 16 Name: Nut 8 B Quantity: 1 Dim.: M8 
Pos. 5 Name: Bolt 8,8 B Quantity: 2 Dim.: M10x110 	Pos. 11 Name: Plain washer Quantity: 2 Dim.: Ø 10,5 mm 	Pos. 17 Name: Spring Quantity: 1 
	Pos. 18 Name: Ball cover Quantity: 1 	



PPUH AUTO-HAK S.J.

Produkcja Zaczepów Kulowych
Henryk & Zbigniew Nejman
76-200 SŁUPSK ul. Słoneczna 16K
tel/fax (059) 8-414-414; 8-414-413
e-mail: office@autohak.com.pl
www.autohak.com.pl

Towing hitch (without electrical set)

Class: **A50-X** Cat. no. **H08**

Designed for:

Manufacturer: **SKODA**

Model: **SUPERB**

produced since 2002 till 08.2008

Technical data:

D-value: 9,93 kN

maximum trailer weight: **1600 kg**

maximum vertical cup mass: **75 kg**

Approval number acc. to regulations EKG/ONZ 55.01: E20-55R-01 0879

Foreword

This towbar is designed according to rules of safety traffic regulations. The towing hitch is a safety component and can be install only by qualified personnel. Any alteration or conversion of the towing hitch is prohibited and would lead to cancellation of design certification. Remove insulating compound and underseal from vehicle (if present) in the area of the matting surfaces of the towing hitch.

The vehicle manufacturer's specifications regarding trailer load and max. vertical cup load are decisive for driving, and values for the towing hitch cannot be exceeded.

D-value formula:

$$\frac{\text{Max trailer weight [kg]} \times \text{Max vehicle weight [kg]}}{\text{Max trailer weight [kg]} + \text{Max vehicle weight [kg]}} \times \frac{9,81}{1000} = D \text{ [kN]}$$